

# LA-5300



LA-5300 makes it easy to capitalize on all the added benefits of ATSC 3.0 Audio, including immersive audio, while giving you the option for backward compatibility with ATSC 1.0!



## Linear Acoustic® LA-5300

The Complete Audio Processor for ATSC 3.0 and 1.0





## Get ATSC 3.0 Audio Workflows, Fast

### ATSC 3.0 Audio Made Easy

Watching TV today is a very different experience than it was just a decade ago. Viewers can watch broadcast TV off the air, from cable and satellite providers, or via streaming services. Media consumption continues to evolve rapidly to match our on-demand lifestyle.

Broadcasters—traditionally restricted to the confines of the “TV set”—finally have the options they need to compete when they adopt ATSC 3.0. For the first time ever, the broadcast platform is built on the same Internet protocol backbone as today’s popular streaming media platforms, allowing broadcasters to break free from the TV set and deliver their content to mobile devices, cars, gaming console—anywhere the viewer wants to see it. ATSC 3.0 also allows broadcasters to play by Internet rules, merging over-the-air (OTA) with over-the-top (OTT) content to give audience members the choices and enhanced experiences they have come to expect from competing platforms.

...everything broadcasters need to be ready for NEXTGEN TV, with the option of backward compatibility for ATSC 1.0 services

The Linear Acoustic LA-5300 Broadcast Audio Processor provides everything broadcasters need to be ready for NEXTGEN TV/ATSC 3.0 audio with the option of backward compatibility for ATSC 1.0 services, addressing the concerns of aging ATSC 1.0 infrastructures while future-proofing the way forward for those needing to update to ATSC 3.0 today.

LA-5300 offers a single, compact, integrated package that includes loudness control, upmixing, encoding, transcoding, audience measurement watermarking, and bitstream analysis for up to four simultaneous real-time program streams along with a confidence monitor output.

# Backwards Compatible with ATSC 1.0



## Features

- Dolby® AC-4 encoding from PCM for stereo, 5.1, and Dolby Atmos® services
- Transcoding from Dolby Digital and Dolby Digital Plus to AC-4
- Optional encoding / transcoding into Dolby Digital and Dolby Digital Plus
- AC-4 / Dolby Digital / Dolby Digital Plus decoding for watermarking and bitstream analysis and monitoring
- Linear Acoustic UPMAX® ISC upmixing
- Optional Verance or Nielsen watermarking
- Dolby Real-Time Loudness Leveler when encoding to AC-4
- Linear Acoustic APTO™ loudness control when encoding to Dolby Digital / Dolby Digital Plus
- Dual 3Gb/s HD/SD-SDI, 5 pairs of AES-3 I/O, and AES67 I/O in support of SMPTE ST 2110-30 and -31 workflows
- Optional Quad-Link 3Gb/s SDI I/O for supporting 4K workflows or MADI I/O (mutually exclusive)
- Dual 1000BaseT Ethernet connections (AES67 and control)
- SNMP alarm and status reporting
- Web-based user interface provides comprehensive setup, configuration, routing, control, and metering



**Get Ready for  
Immersive Audio**

## **A Complete ATSC 3.0/NEXTGEN TV and ATSC 1.0 Audio Solution**

The rollout of ATSC 3.0—better known to consumers as NEXTGEN TV—offers great benefits for both the broadcaster and the viewer alike. New features such as personalization, dialog enhancement, and immersive audio all bring a more enriching experience to your audience. For the broadcaster, ATSC 3.0 helps generate revenue with watermarking. While ratings watermarking is not new, modern implementations of watermarking yield ratings data that is consistent and reliable. ATSC 3.0 also brings with it a unique set of requirements, challenges, and opportunities for television broadcasters.

**...LA-5300 meets the immediate requirements for NEXTGEN TV/ATSC 3.0 audio right out of the box...**

The Linear Acoustic LA-5300 provides a single solution for loudness control, upmixing, decoding AC-4 for audience measurement watermark insertion, bitstream analysis, and monitoring, transcoding of Dolby® Digital and Dolby Digital Plus to AC-4, and Dolby AC-4 encoding.

The LA-5300 can also handle all of your audio processing needs for today's ATSC 1.0 services and feeds to MVPDs with an optional software upgrade that uses the same processing techniques available for ATSC 3.0 paths with the final encoded signal being Dolby Digital or Dolby Digital Plus instead of Dolby AC-4.

The ability to handle up to 4 programs means one LA-5300 can provide unique encoded streams for the main program audio, SAP, and video descriptive services—all in a single 1RU solution. A decode and monitor-only version is also available which omits upmixing, watermarking, and AC-4 encoding.

**Ready for Today,  
Ready for Tomorrow**



## I/O for Any Facility

The LA-5300 comes standard with 5 pairs of AES-3 I/O, dual 3G SDI I/O, and AES67 I/O to support SMPTE ST 2110-30 and -31 workflows. Options include Quad-Link 3G SDI for facilities utilizing 4K workflows, or MADI I/O. Two Gigabit Ethernet ports are provided, one for AES67, and one for remote control via the web-based GUI.

The LA-5300 meets the immediate requirements for NEXTGEN TV/ATSC 3.0 audio right out of the box, with channel-based AC-4 encoding, loudness control, and upmixing to either 5.1 or immersive audio (Dolby Atmos®) configurations for multiple programs. As ATSC 3.0 adoption grows, support for its additional features and benefits such as object-based audio, interactive consumer control, personalized audio, and multiple presentations within a single stream will be incorporated into the LA-5300 via software updates.



## MVPD Turn-Around Workflow

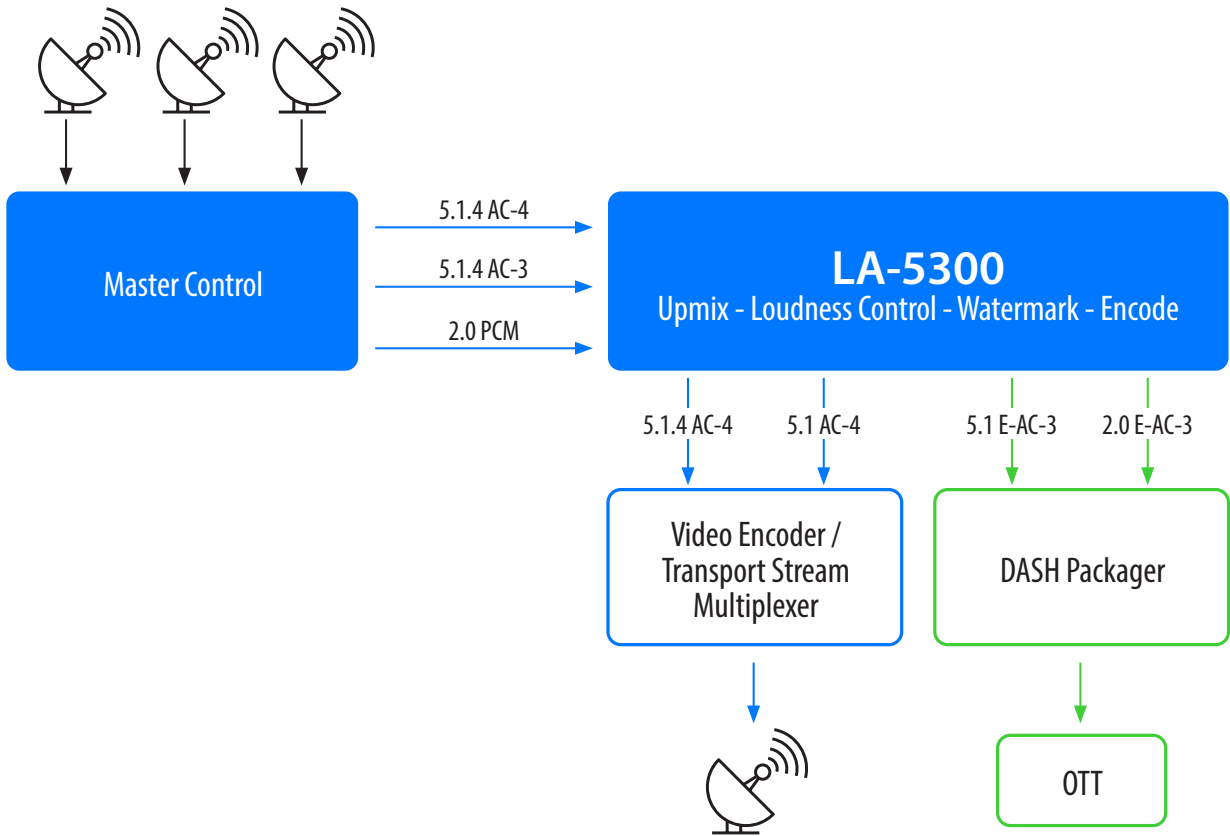



## ATSC 1.0 / 3.0 Simulcast

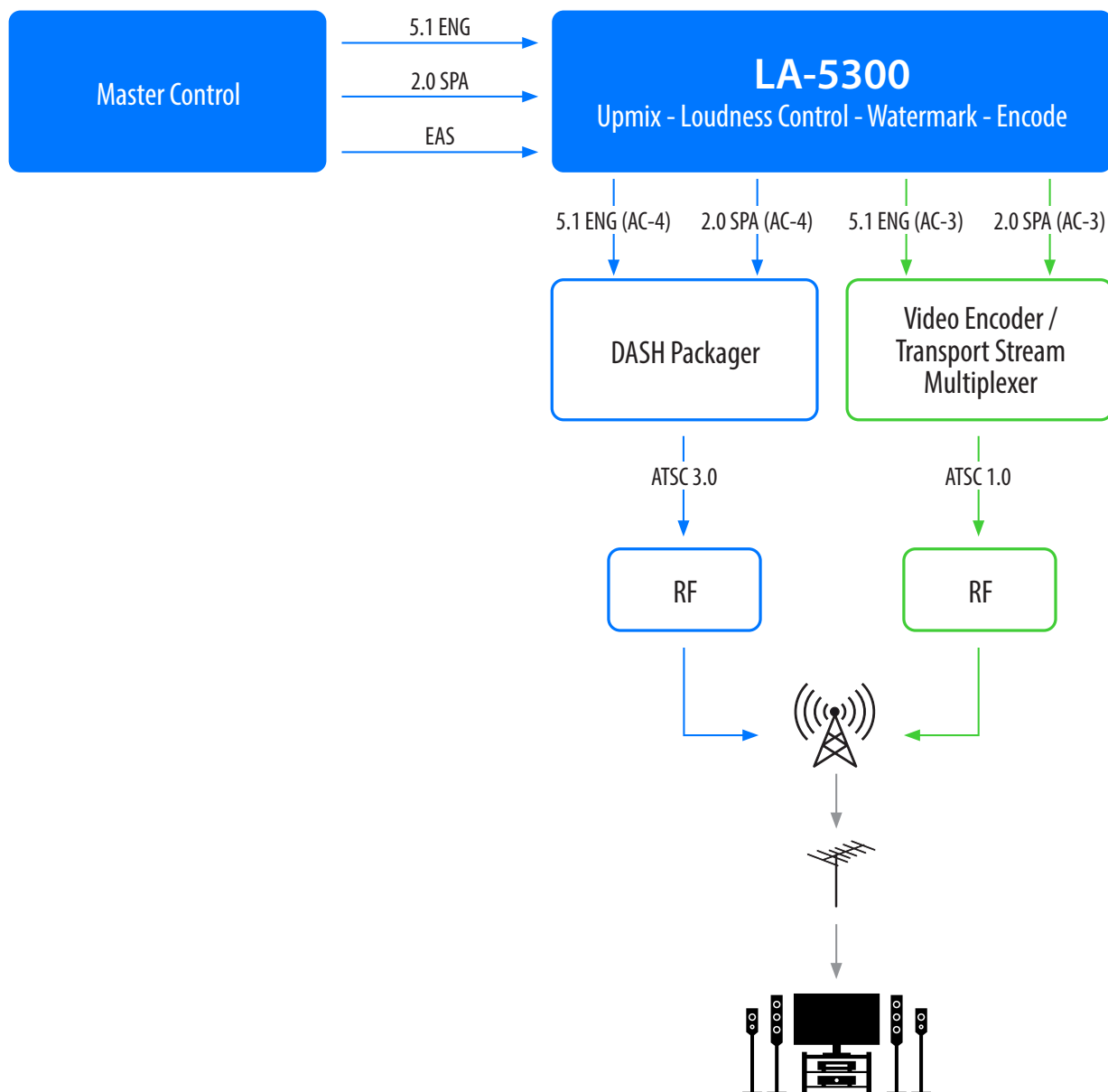



## AC-4 Encoder Block Diagram

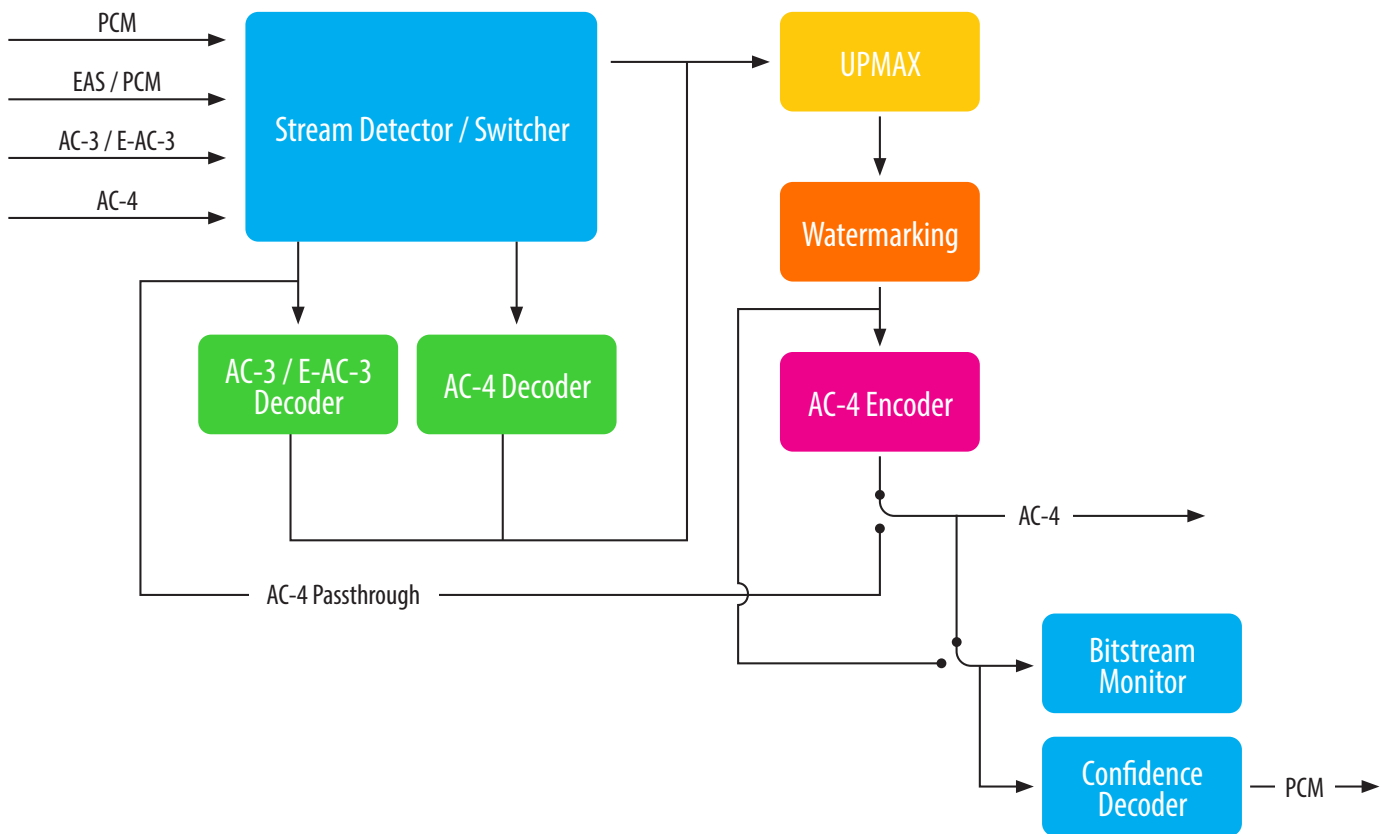



# Legendary UPMAX ISC for Upmixing to 5.1 or Immersive



## Specifications

### Processing

- Processing for up to 4 independent program streams
- Linear Acoustic UPMAX ISC® upmixing to 5.1 or immersive configurations
- Dolby® Real-Time Loudness Leveler (RTL) when encoding to AC-4
- Linear Acoustic APTO™ Loudness Control when encoding to Dolby Digital / Dolby Digital Plus
- Optional Nielsen and Verance audience measurement watermarking

### Decoding

- Decodes Dolby AC-4, Dolby Digital, or Dolby Digital Plus at the input for watermarking and monitoring with AC-4 passthrough ability

### Transcoding

- Transcodes Dolby Digital and Dolby Digital Plus to Dolby AC-4
- Optional transcoding of Dolby AC-4 to Dolby Digital / Dolby Digital Plus

### Encoding

- Encodes to Dolby AC-4
- Optional encoding to Dolby Digital (AC-3) / Dolby Digital Plus (E-AC-3)

### Watermarking

- Optional Nielsen and Verance audience measurement watermarking

### Bitstream Analysis and Monitoring

- Bitstream analysis of all streams simultaneously plus a confidence monitoring output for one stream at a time



# Decodes AC-4, Dolby Digital, Dolby Digital Plus

## HD/SD-SDI I/O

- Two independent auto-sensing 3Gb/s HD/SD-SDI inputs (SMPTE ST 425-1, 292M, and 259M) up to 1080p/60/59.94/50Hz, each with de-embedding/re-embedding for up to 8 audio pairs
- Optional Quad-Link 3Gb/s SDI for 4k workflows (mutually exclusive with MADI option)

## AES-3 I/O

- 5 inputs/outputs via 75 Ohm BNC unbalanced female connectors, internally terminated; signal levels per SMPTE 276M/AES-31D-2001

## AES67 I/O

- 16 channels of bi-directional AES67 I/O in support of SMPTE ST 2110-30 and -31 workflows

## MADI I/O

- Optional MADI I/O supports up to 32 channels for processing (mutually exclusive with Quad-Link SDI option)
- Passthrough and shuffling for up to 64 channels
- I/O via coax or optical SFP socket (SFP sold separately)

## Clock Reference

- 48kHz reference via SDI, PTP, AES-3, internal clock (standalone use only), or
- MADI (when MADI option is installed)
- Vref

## Sample Rate/Resolution/Frequency Response

- 48kHz, 24-bit, 20Hz - 20kHz

# Available with Nielsen & Verance Watermarking



## Ethernet

- Two Gigabit RJ-45 connections - one for AES67, one for networked remote control

## Parallel GPI/O Control Port

- 15-pin female D connector, 0-5V TTL levels, 5 GPI/O inputs, 5 GPI/O outputs

## Power

- Dual internal redundant auto-ranging power supplies
- 95-240 VAC, 50/60 Hz, 100W maximum total

## Dimensions and Weight

- 19" W x 15.5" D x 1.75" H (approximately 48.2 x 39.4 x 4.5 cm )
- Net weight: Approximately 9.0 lbs (4.08 kg)
- Approximate shipping weight 16 lbs (7.26 kg)

## Regulatory

- North America - FCC and CE tested and compliant with UL-approved power supplies
- Europe - Complies with European Union Directive 2011/65/EU of the European Parliament and of the Council of 8 June 2011 on the restriction of the use of certain hazardous substances in electrical and electronic equipment (RoHS)
- Compliant with the CE EN 62368-1:2018 requirements

## Warranty

- Standard Telos Alliance 2-year limited parts and labor



Dolby®, Dolby Atmos®, Dolby Audio, and the double-D symbol are trademarks of Dolby Laboratories. The NEXTGEN TV logo is an unregistered trademark of the Consumer Technology Association and is used by permission.